

SKYWORDS

The Newsletter of :
Burlington Radio Control Modelers Club
P.O.Box 85174 Burlington Ontario L7R 4K4
WWW.BRCM.org

October 2012

Next meeting
Thursday October 25th
7:30 PM
Burlington Main Library
New Street

Bring a Plane
or an Idea to share

Lawrence Cragg will talk about the visit to UK airfields by four club members and the subsequent international repercussions.

Ivan Wismeyer will explain how he got into a Spitfire by mistake.

We may also have a juggler and a Lion Tamer



Avro Vulcan XH558 (civil aircraft registration (G-VLCN) "The Spirit Of Great Britain" is the only airworthy example of the 134 Avro Vulcan "V" bombers that were operated by the Royal Air Force from 1953 until 1984. Vulcan XH558 served with the RAF between 1960 and 1985 in the bomber, maritime reconnaissance and air-to-air refuelling roles. The RAF operated XH558 as a display aircraft from 1986 until 1992, when budget cuts forced its retirement.

It is presently operated by the "Vulcan to the Sky" Trust as a display aircraft, funded entirely by charitable donations and the UK Lottery's Heritage Fund.

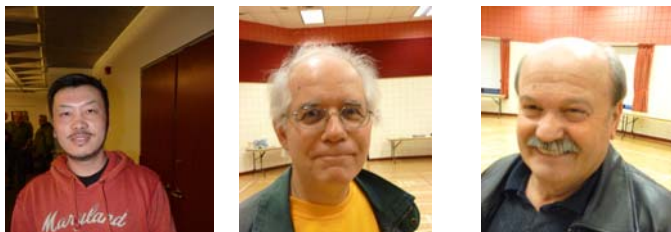

3 Fine members Lto R, Max Xu, Bill Montgomery and Branco Jazvac

BURLINGTON

RADIO CONTROL MODELERS

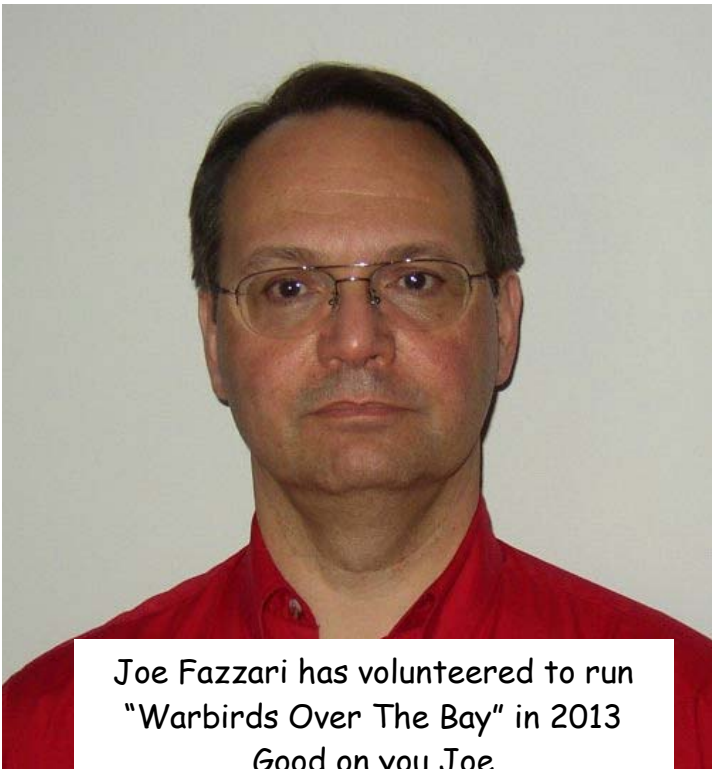

Joe Fazzari has volunteered to run "Warbirds Over The Bay" in 2013
Good on you Joe



This is in Munich I think. Lawrence will explain at the October meeting



A bunch of old stuff in a field, both sides of the fence.



No comment needed for this I think.

USS Enterprise
Below is a 1/72 scale model of The USS Enterprise built over a 19 year period by Gabe Suranyi. Gabe spent 2 days on the Enterprise courtesy of the Captain. The model is 16' long and 4' wide. Can't even begin to estimate how many bits are involved but there are over 6000 tie downs on the flight deck!



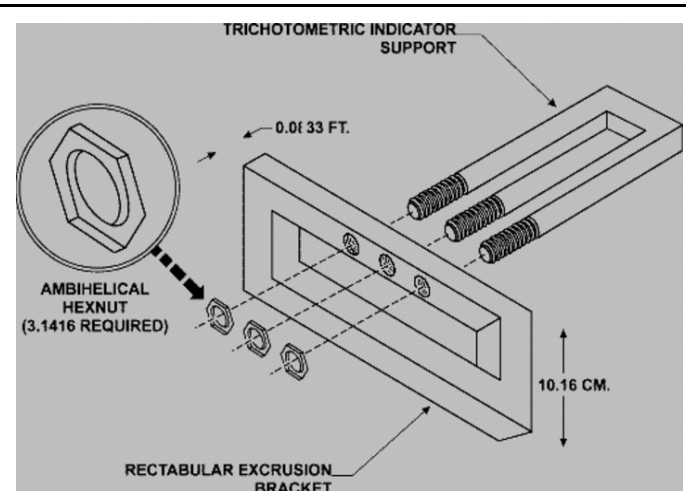

This is from Bill Swindells which might explain some of his models.

Winter of 1911

Niagara Falls frozen over

When I first came to Canada in January 1970 it was the coldest winter in years and Niagara Falls

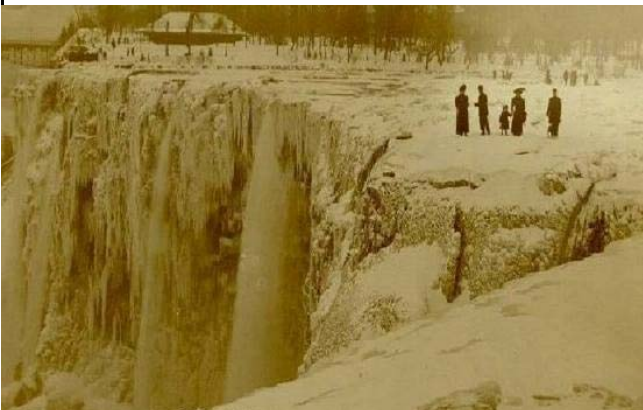

were almost like this, not quite but almost. We wondered what the hell we had got ourselves into. I didn't even own a proper winter coat and Kay had Mini Mini skirts as was the fashion. I went to Edmonton at the end of January dressed in my English winter overcoat and a little scarf, no hat, no gloves and in those days we had to walk from the Viscount to the terminal across about 100 feet of apron, it was minus 35, I didn't think I was going to make it!

They say there is a whole new generation of Golden Horseshoers that have never experienced a real Ontario Winter.

Lucky them!

Tom

Russian Funny-Stuff

I was recently in Moscow and spied a strange airplane looking object across the Volga from our boat. Turns out it is an "Ago Orlyonok" ground effects vehicle.



A ground effect vehicle (GEV) is one that attains level flight near the surface of the Earth, making use of the aerodynamic interaction between the wings and the surface known as ground effect. GEV are also known as a wing-in-ground-effect (WIG) vehicle, flarecraft, sea skimmer, ekranoplan, SkimMachine, or a wing-in-surface-effect ship (WISE). (all this from Wikipedia)

In recent years a large number of different GEV types have been developed for both civilian and mili-



tary use. However, these craft are not in general use. Here is another example the "Lun Ekranoplan" with 8 turbojets, 6 crew 6 ship to ship missiles and a speed of 550 KPH. Built in 1987 the Russian navy is said to be still interested in getting some.

Where else but Skywords would you find this stuff?